

**STRONG.
ENCAPSULATED.
EFFICIENT.**



SHAKTI SUBMERSIBLE MOTORS
4" PREMIUM 100/101
PRODUCT INFORMATION & SERVICE MANUAL

SHAKTI
PUMPING LIFE

www.shaktipumps.com

VISION, MISSION & QUALITY POLICY



www.shaktipumps.com

VISION

To become a company that constantly strives for quality and customer satisfaction by providing best pumping solutions with global benchmarks. To excel with an emphasis on best business and ethical practices with strong organizational values justifying the interests of all stakeholders.

MISSION

To work relentlessly towards coming closer to our vision statement by offering best working environment and training focusing on integrity and ethics. To empower the workforce to offer products and services that exceeds customer expectations by providing value for money and ensure handsome return to our employees and shareholders thereby contributing to our mission to cross a \$ billion mark by 2021.

QUALITY POLICY

Shakti Pumps (I) Ltd. is committed to achieve total customer satisfaction by manufacturing high quality pumps with global bench mark meeting customer expectation by providing timely supply and services to our customers. We shall strive to maintain high degree of goodwill and brand image to emerge as a market leader in domestic and international markets.

We shall strive for providing excellent services to our customers by team work and continual improvement of Quality Management Systems thereby achieving total customer delight.

CONTENT

4" PREMIUM ENCAPSULATED PRODUCT INFORMATION

PAGE NO.

Product Application and Product Specification	2
Model Numbers 304/316 SS 50/60 Hz	3-5
Motor Performance data Single Phase 50Hz	6
Motor Performance data Single Phase 60Hz	7
Motor Performance data Three Phase 50Hz	8-9
Motor Performance data Three Phase 60Hz	9-10
Motor Length & Weight SS 304/SS316 Single/Three Phase	11
Motor Outline Drawings	12
Motor Sectional View Material Construction PREMIUM 100	13
Motor Sectional View Material Construction PREMIUM 101	14

4" PREMIUM ENCAPSULATED SPARE PARTS

Motor assly exploded view PREMIUM-100 SS 304	15
Sectional view PREMIUM - 100 SS 304	16
Part list exploded view PREMIUM- 100 SS 304	17
Motor assly exploded view PREMIUM-100 SS 316	18
Sectional view PREMIUM - 100 SS 316	19
Part list exploded view PREMIUM- 100 SS 316	20
Motor assly exploded view PREMIUM-101 SS 304	21
Sectional view PREMIUM - 101 SS 304	22
Part list exploded view PREMIUM- 101 SS 304	23
Motor assly exploded view PREMIUM-101 SS 316	24
Sectional view PREMIUM - 101 SS 316	25
Part list exploded view PREMIUM- 101 SS 316	26
Replacement Stator & Rotor Spare Parts numbers	27-28

4" ENCAPSULATED PREMIUM MOTOR



PRODUCT APPLICATION AND PRODUCT SPECIFICATION

www.shaktipumps.com

GENERAL DATA

Single Phase & Three Phase Motor

Shakti 3-Wire motor are single phase , Capacitor start induction run (CSIR) or capacitor start -Capacitor run (CSCR) motor optimised for operation with the shakti control Boxes. This design features the highest starting torque within the single phase motor range. Control Boxes include all necessary long-life starting and motor protection relays and capacitors.

Applications

This motor is built for dependable operation in 4" diameter or larger water wells. It is fitted with water lubricated radial and thrust bearings for a maintenance -free operations. The motor is filled with a special fluid, Providing frost protection down to -15°C. A Special diaphragm ensures pressure compensation inside the motor.

Product advantages:

- Hermetically sealed stator. Anti track, self healing stator resin prevents motor burn out.
- High efficiency electrical design (low operation cost, cooler winding temperature)
- Removable " Water Bloc" lead connector
- Cable material in accordance with regulations for drinking water
- water lubricated radial and thrust bearings
- All motors pre-filled and 100 % tested.
- Non contaminating, water-filled design.

Technical Specification

- 4" NEMA flange
- Rotation : CCW facing shaft end.
- Degree of protection : Ip68
- Insulation : Cl .B
- Rated Ambient temp.:30°C
- Cooling flow: Motor 2,2 kW and larger: min 8cm/sec.
- Starts/hr:20
- Mounting : Vertical/horizontal
Voltage tolerance : $\pm 6\%$ /-10% UN
- Motor protection : Included Shakti Control Boxes

Options

- Motor cable approved (1,5mm; special lengths available).
- Complete 316SS Motor with SiC seal.
- Built-in lightning arrestor.

4" ENCAPSULATED PREMIUM MOTOR

MODEL NUMBERS 304/316 SS 50/60 HZ

SUBMERSIBLE MOTORS			
Material	Stainless Steel 304/316	Rating	0.37 kW - 7.5 kW
Type	Encapsulated	Thrust Rating	1500 - 6500 N

MODEL NUMBERS

4" PREMIUM MOTORS- MODEL NUMBER 50/60 Hz

MODEL	HP	KW	(V)/HZ	MODEL - A CONNECTION - STAR	
				304	316
PREMIUM 100	0.5	0.37	380/400/415 50HZ 415/460 60 HZ	9000008274	9000013218
PREMIUM 100	0.75	0.55	380/400/415 50HZ 415/460 60 HZ	9000008275	9000013219
PREMIUM 100	1	0.75	380/400/415 50HZ 415/460 60 HZ	9000008276	9000013220
PREMIUM 100	1.5	1.1	380/400/415 50HZ 415/460 60 HZ	9000008277	9000013221
PREMIUM 100	2	1.5	380/400/415 50HZ 415/460 60 HZ	9000008278	9000013222
PREMIUM 100	3	2.2	380/400/415 50HZ 415/460 60 HZ	9000008305	9000013223
PREMIUM 100	4	3	380/400/415 50HZ 415/460 60 HZ	9000008306	9000013224
PREMIUM 100	5	3.7	380/400/415 50HZ 415/460 60 HZ	9000008307	9000013225
PREMIUM 101	5.5	4.0	380/400/415 50HZ 415/460 60 HZ	9000013312	9000013315
PREMIUM 101	7.5	5.5	380/400/415 50HZ 415/460 60 HZ	9000008309	9000013227
PREMIUM 101	10	7.5	380/400/415 50HZ 415/460 60 HZ	9000008310	9000013228

MODEL	HP	KW	(V)/HZ	MODEL - E CONNECTION - INNER DELTA	
				304	316
PREMIUM 100	0.5	0.37	230 60HZ	9000008280	9000013229
PREMIUM 100	0.75	0.55	230 60HZ	9000008281	9000013230
PREMIUM 100	1	0.75	230 60HZ	9000008282	9000013231
PREMIUM 100	1.5	1.1	230 60HZ	9000008283	9000013232
PREMIUM 100	2	1.5	230 60HZ	9000008284	9000013233
PREMIUM 100	3	2.2	230 60HZ	9000008311	9000013234
PREMIUM 100	4	3	230 60HZ	9000008312	9000013235
PREMIUM 100	5	3.7	230 60HZ	9000008313	9000013236
PREMIUM 101	5.5	4.0	230 60HZ	9000013313	9000013316
PREMIUM 101	7.5	5.5	230 60HZ	9000008315	9000013238
PREMIUM 101	10	7.5	230 60HZ	9000008316	9000013239

4" ENCAPSULATED PREMIUM MOTOR

MODEL NUMBERS 304/316 SS 50/60 HZ



www.shaktipumps.com

SUBMERSIBLE MOTORS			
Material	Stainless Steel 304/316	Rating	0.37 kW - 7.5 kW
Type	Encapsulated	Thrust Rating	1500 - 6500 N

MODEL NUMBERS

4" PREMIUM MOTORS- MODEL NUMBERS 50/60 Hz

MODEL	HP	KW	(V)/HZ	MODEL - F CONNECTION - STAR	
				304	316
PREMIUM 100	0.5	0.37	380 60HZ	9000008286	9000013240
PREMIUM 100	0.75	0.55	380 60HZ	9000008287	9000013241
PREMIUM 100	1	0.75	380 60HZ	9000008288	9000013242
PREMIUM 100	1.5	1.1	380 60HZ	9000008289	9000013243
PREMIUM 100	2	1.5	380 60HZ	9000008290	9000013244
PREMIUM 100	3	2.2	380 60HZ	9000008317	9000013245
PREMIUM 100	4	3	380 60HZ	9000008318	9000013246
PREMIUM 100	5	3.7	380 60HZ	9000008319	9000013247
PREMIUM 101	5.5	4.0	380 60HZ	9000013314	9000013317
PREMIUM 101	7.5	5.5	380 60HZ	9000008321	9000013249
PREMIUM 101	10	7.5	380 60HZ	9000008322	9000013250

4" ENCAPSULATED PREMIUM MOTOR

MODEL NUMBERS 304/316 SS 50/60 HZ

SUBMERSIBLE MOTORS			
Material	Stainless Steel 304/316	Rating	0.37 kW - 7.5 kW
Type	Encapsulated	Thrust Rating	1500 - 6500 N

MODEL NUMBERS

4" PREMIUM MOTORS-MODEL NUMBER 50/60 HZ

MODEL	HP	KW	(V)/HZ	MODEL - G CONNECTION - STAR	
				304	316
PREMIUM 100	0.5	0.37	230 50HZ	9000008292	9000013251
PREMIUM 100	0.75	0.55	230 50HZ	9000008294	9000013252
PREMIUM 100	1	0.75	230 50HZ	9000008295	9000013253
PREMIUM 100	1.5	1.1	230 50HZ	9000008296	9000013254
PREMIUM 100	2	1.5	230 50HZ	9000008297	9000013255
PREMIUM 100	3	2.2	230 50HZ	9000008323	9000013256
PREMIUM 101	5	3.7	230 50HZ	9000008325	9000013258

MODEL	HP	KW	(V)/HZ	MODEL - H	
				304	316
PREMIUM 100	0.5	0.37	230 60HZ	9000008299	9000013259
PREMIUM 100	0.75	0.55	230 60HZ	9000008300	9000013260
PREMIUM 100	1	0.75	230 60HZ	9000008301	9000013261
PREMIUM 100	1.5	1.1	230 60HZ	9000008302	9000013262
PREMIUM 100	2	1.5	230 60HZ	9000008303	9000013263
PREMIUM 100	3	2.2	230 60HZ	9000008329	9000013264
PREMIUM 101	5	3.7	230 60HZ	9000008331	9000013266

4" ENCAPSULATED PREMIUM MOTOR

MOTOR PERFORMANCE DATA SINGLE PHASE 50HZ



www.shaktipumps.com

SUBMERSIBLE MOTORS			
Material	Stainless Steel 304/316	Rating	0.37 kW - 7.5 kW
Type	Encapsulated	Thrust Rating	1500 - 6500 N

SINGLE PHASE PERFORMANCE DATA 50 HZ (MODEL-G) SS304/SS316 - PREMIUM 100

P _N [HP]	P _N [KW]	Thrust F [N]	U _N [V]	N _n [min 1]	S.F	I _N [A]	MAXIMUM [S.F LOAD AMP]	I _A [A]	η(Eff.)[%]			COS Φ (PF.)			T _N [Nm]	T _A [Nm]
									at % load			at % load				
									50	75	100	50	75	100		
0.5	0.37	1500	230	2890	1.6	B4.2	B5.2	14.4	51	59	62	0.52	0.6	0.62	2	1.2
						R3.9	R4.9									
						Y1.72	Y1.72									
0.75	0.55	1500	230	2900	1.5	B4.4	B5.8	23.1	52	59	63	0.48	0.59	0.86	2.7	1.8
						R3.7	R5									
						Y2.15	Y2.15									
1	0.75	1500	230	2890	1.4	B6.9	B8.3	28.3	56	62	64	0.54	0.66	0.73	4.1	2.5
						R6.4	R7.5									
						Y3.4	Y3.4									
1.5	1.1	3000	230	2890	1.3	B8.2	B10	39.6	58	65	68	0.59	0.71	0.85	6	3.7
						R7.4	R9.2									
						Y3.9	Y3.9									
2	1.5	3000	230	2875	1.25	B10.6	B12.5	53.4	60	66	68	0.71	0.81	0.9	8.3	4.9
						R6.9	R8.8									
						Y6.0	Y6.0									

SINGLE PHASE PERFORMANCE DATA 50 HZ (MODEL-G) SS304/SS316 - PREMIUM 101

P _N [HP]	P _N [KW]	Thrust F [N]	U _N [V]	N _n [min1]	S.F	I _N [A]	MAXIMUM [S.F LOAD AMP]	I _A [A]	η(Eff.)[%]			COS Φ (PF.)			T _N [Nm]	T _A [Nm]
									at % load			at % load				
									50	75	100	50	75	100		
3	2.2	4000	230	2885	1.15	B14	B15.2	80.0	61	68	70	0.72	0.82	0.97	14	7.4
						R9.7	R10.9									
						Y6.5	Y6.5									
4	3	6500	230	2830	1.15	B19	B20.0	88.0	61	68	72	0.69	0.7	0.95	18	8.2
						R15.2	R16.8									
						Y6.8	Y6.8									
5	3.7	6500	230	2885	1.15	B22.2	B26.5	121	69	75	76	0.9	0.93	0.95	21	12.3
						R18	R22.1									
						Y7.2	Y7.2									

4" ENCAPSULATED PREMIUM MOTOR

MOTOR PERFORMANCE DATA SINGLE PHASE 60HZ

SUBMERSIBLE MOTORS			
Material	Stainless Steel 304/316	Rating	0.37 kW - 7.5 kW
Type	Encapsulated	Thrust Rating	1500 - 6500 N

SINGLE PHASE PERFORMANCE DATA 60 HZ (MODEL-H) SS304/SS316 - PREMIUM 100

P _N [HP]	P _N [KW]	Thrust F [N]	U _N [V]	N _n [min1]	S.F	I _N [A]	MAXIMUM [S.F LOAD AMP]	I _A [A]	η(Eff.)[%]			COS Φ (PF.)			T _N [Nm]	T _A [Nm]
									at % load			at % load				
									50	75	100	50	75	100		
0.5	0.37	1500	230	3450	1.6	Y5.0	Y6.0	14.8	48	52	55	0.45	0.50	0.58	3	2.1
						B5.0	B6.0									
						R0	R0									
0.75	0.55	1500	230	3450	1.5	Y6.7	Y8.0	26.8	52	55	59	0.41	0.53	0.60	3.5	2.7
						B6.7	B8.0									
						R0	R0									
1	0.75	1500	230	3450	1.4	Y8.0	Y9.4	38.3	56	60	62	0.44	0.54	0.65	5.5	3.2
						B8.0	B9.4									
						R0	R0									
1.5	1.1	3000	230	3450	1.3	Y9	Y10.8	42.3	59	63	66	0.52	0.60	0.80	7.2	4.8
						B8.9	B10.3									
						R1.3	R1.3									
2	1.5	3000	230	3450	1.25	Y10.4	Y12.3	53.4	60	66	74	0.66	0.82	0.88	10	5.4
						B9.7	B11.6									
						R2.6	R2.6									

SINGLE PHASE PERFORMANCE DATA 60 HZ (MODEL-H) SS304/SS316 - PREMIUM 101

P _N [HP]	P _N [KW]	Thrust F [N]	U _N [V]	N _n [min 1]	S.F	I _N [A]	MAXIMUM [S.F LOAD AMP]	I _A [A]	η(Eff.)[%]			COS Φ (PF.)			T _N [Nm]	T _A [Nm]
									at % load			at % load				
									50	75	100	50	75	100		
3	2.2	4000	230	3450	1.15	Y14.0	Y17.0	60.0	67	70	75	0.70	0.85	0.91	15	8.2
						B12.2	B14.5									
						R4.7	R4.5									
4	3	6500	230	3450	1.15	Y18.2	Y19.5	80.0	67	72	75	0.76	0.88	0.95	19	9.6
						B14.2	B15.2									
						R6.2	R6.0									
5	3.7	6500	230	3450	1.15	Y23.0	Y27.5	120.0	70	75	77	0.71	0.86	0.90	22	13.2
						B19.1	B23.2									
						R8.0	R7.8									

4" ENCAPSULATED PREMIUM MOTOR



MOTOR PERFORMANCE DATA THREE PHASE 50HZ

www.shaktipumps.com

SUBMERSIBLE MOTORS			
Material	Stainless Steel 304/316	Rating	0.37 kW - 7.5 kW
Type	Encapsulated	Thrust Rating	1500 - 6500 N

THREE PHASE PERFORMANCE DATA 50 HZ SS304/SS316 - PREMIUM 100

P _N [HP]	P _N [KW]	Thrust F [N]	U _N [V]	N _n [min1]	S.F	I _N [A]	MAXIMUM [S.F LOAD AMP]	I _A [A]	η(Eff.)[%]			COS Φ (PF.)			T _N [Nm]	T _A [Nm]
									at % load			at % load				
									50	75	100	50	75	100		
0.5	0.37	1500	380	2840	1.6	1.9	1.3	4.4	59	64	66	0.57	0.69	0.76	1.2	2.3
			400	2865	1.6	1.9	1.3	4.7	56	63	66	0.53	0.65	0.7	1.2	2.5
			415	2875	1.6	1.1	1.4	4.9	54	62	66	0.49	0.6	0.76	1.2	2.8
0.75	0.55	1500	380	2830	1.5	1.6	1.9	6.0	61	67	67	0.59	0.72	0.8	1.9	3.1
			400	2855	1.5	1.6	1.9	6.4	58	64	67	0.54	0.67	0.75	1.9	3.5
			415	2870	1.5	1.7	2.0	6.6	55	63	66	0.5	0.63	0.8	1.9	3.7
1	0.75	1500	380	2850	1.4	2.1	2.5	8.9	63	68	70	0.57	0.7	0.79	2.5	4.8
			400	2870	1.4	2.1	2.5	9.3	60	67	69	0.52	0.65	0.75	2.5	5.3
			415	2880	1.4	2.2	2.6	9.8	57	65	68	0.49	0.61	0.71	2.5	5.9
1.5	1.1	3000	380	2820	1.3	3	3.6	13.8	69	72	72	0.59	0.73	0.81	3.8	9.6
			400	2840	1.3	3	3.6	14.5	66	71	73	0.53	0.67	0.76	3.7	10.6
			415	2860	1.3	3.1	3.7	15.3	64	70	72	0.49	0.62	0.72	3.7	11.5
2	1.5	3000	380	2840	1.25	3.9	4.6	18.6	69	72	73	0.59	0.72	0.81	5.0	11.3
			400	2855	1.25	4	4.7	19.2	66	71	73	0.53	0.66	0.76	5.0	12.6
			415	2870	1.25	4.1	4.8	20.2	63	69	72	0.48	0.61	0.72	4.9	13.5

4" ENCAPSULATED PREMIUM MOTOR

MOTOR PERFORMANCE DATA THREE PHASE 50HZ

SUBMERSIBLE MOTORS			
Material	Stainless Steel 304/316	Rating	0.37 kW - 7.5 kW
Type	Encapsulated	Thrust Rating	1500 - 6500 N

THREE PHASE PERFORMANCE DATA 50 HZ SS304/SS316 - PREMIUM 101

P _N [HP]	P _N [KW]	Thrust F [N]	U _N [V]	N _n [min ⁻¹]	S.F	I _N [A]	MAXIMUM [S.F LOAD AMP]	I _A [A]	η(Eff.)[%]			COS Φ (PF.)			T _N [Nm]	T _A [Nm]
									at % load			at % load				
									50	75	100	50	75	100		
3	2.2	4000	380	2815	1.15	5.8	6.4	28.7	72	75	75	0.58	0.72	0.81	7.6	21.7
			400	2840	1.15	5.8	6.4	28.9	69	73	75	0.51	0.64	0.75	7.5	23.6
			415	2870	1.15	6.3	6.9	30.8	66	71	73	0.45	0.59	0.69	7.5	25.9
4	3	4000	380	2830	1.15	7.5	8.2	39.9	73	76	76	0.58	0.72	0.81	10	27.6
			400	2850	1.15	7.8	8.6	41.6	70	74	76	0.51	0.65	0.75	9.9	31.5
			415	2860	1.15	8.2	9.0	43.3	67	73	75	0.46	0.59	0.7	9.9	33.8
5	3.7	6500	380	2830	1.15	9	9.9	46	75	78	77	0.64	0.76	0.84	34.9	12.5
			400	2850	1.15	9.1	10.0	49	73	77	77	0.55	0.7	0.79	38.8	12.4
			415	2860	1.15	9.4	10.3	50	71	76	76	0.51	0.64	0.74	41.6	12.4
6	4.5	6500	380	2835	1.15	9.8	10.8	55	75	78	77	0.63	0.76	0.84	41.6	13.8
			400	2855	1.15	10	11.0	58	73	77	78	0.56	0.69	0.78	46.1	13.7
			415	2870	1.15	10	11.0	60	71	76	77	0.5	0.63	0.73	49.5	13.6
7.5	5.5	6500	380	2830	1.15	13.5	14.3	72	73	76	76	0.64	0.76	0.81	46.7	18.8
			400	2850	1.15	13.7	14.3	76	71	75	76	0.57	0.7	0.76	51.8	18.7
			415	2860	1.15	14.2	15.4	79	69	74	75	0.52	0.65	0.71	55.7	18.6
10	7.5	6500	380	2800	1.15	18.3	20.1	96	70	74	77	0.53	0.65	0.84	81.2	25.2
			400	2820	1.15	18.4	19.8	97	70	73	74	0.47	0.57	0.79	89.9	25.1
			415	2820	1.15	17.4	18.7	102	74	77	77	0.56	0.7	0.77	81.2	25.2

4" ENCAPSULATED PREMIUM MOTOR



MOTOR PERFORMANCE DATA THREE PHASE 60HZ

www.shaktipumps.com

SUBMERSIBLE MOTORS			
Material	Stainless Steel 304/316	Rating	0.37 kW - 7.5 kW
Type	Encapsulated	Thrust Rating	1500 - 6500 N

THREE PHASE PERFORMANCE DATA 60 HZ SS304/SS316 - PREMIUM 100

P _N [HP]	P _N [KW]	Thrust F [N]	U _N [V]	N _n [min1]	S.F	I _N [A]	MAXIMUM [S.F LOAD AMP]	I _A [A]	η(Eff.)[%]			COS Φ (PF.)			T _N [Nm]	T _A [Nm]
									at % load			at % load				
									50	75	100	50	75	100		
0.5	0.37	1500	230	3480	1.6	2.5	3.0	15	60	67	70	0.35	0.44	0.53	1.6	3.5
			380		1.6	1.5	1.8	9.1	60	67	70	0.35	0.44	0.53		
			460		1.6	1.3	1.5	7.5	60	67	70	0.35	0.44	0.53		
0.75	0.55	1500	230	3475	1.5	3.4	4.1	21.4	65	71	73	0.37	0.46	0.55	2.3	5.0
			380		1.5	2.1	2.5	13	65	71	73	0.37	0.46	0.55		
			460		1.5	1.7	2.0	10.7	65	71	73	0.37	0.46	0.55		
1	0.75	1500	230	3470	1.4	4.2	5.0	27	65	70	72	0.4	0.51	0.62	2.9	6.8
			380		1.4	2.6	3.0	16.3	65	70	72	0.4	0.51	0.62		
			460		1.4	2.1	2.4	13.5	65	70	72	0.4	0.51	0.62		
1.5	1.1	3000	230	3430	1.3	4.9	5.9	31.2	69	73	74	0.54	0.65	0.76	4.0	9.8
			380		1.3	3.0	3.6	18.9	69	73	74	0.54	0.65	0.76		
			460		1.3	2.5	2.9	15.6	69	73	74	0.54	0.65	0.76		
2	1.5	3000	230	3440	1.25	6.9	8.1	43.2	68	73	74	0.52	0.63	0.74	5.2	13.8
			380		1.25	4.2	4.9	26.1	68	73	74	0.52	0.63	0.74		
			460		1.25	3.2	3.7	21.6	68	73	74	0.52	0.63	0.74		

THREE PHASE PERFORMANCE DATA 60 HZ SS304/SS316 - PREMIUM 101

P _N [HP]	P _N [KW]	Thrust F [N]	U _N [V]	N _n [min 1]	S.F	I _N [A]	MAXIMUM [S.F LOAD AMP]	I _A [A]	η(Eff.)[%]			COS Φ (PF.)			T _N [Nm]	T _A [Nm]
									at % load			at % load				
									50	75	100	50	75	100		
3	2.2	4000	230	3435	1.15	9.8	10.8	64.4	71	75	77	0.54	0.68	0.73	7.2	20.7
			380		1.15	5.9	6.6	39.0	71	75	77	0.54	0.68	0.73		
			460		1.15	4.9	5.4	32.2	71	75	77	0.54	0.68	0.73		
4	3	4000	230	3440	1.15	12.5	13.8	94.8	72	77	79	0.52	0.66	0.76	9.5	22.3
			380		1.15	7.6	8.3	57.4	72	77	79	0.52	0.66	0.76		
			460		1.15	6.3	6.9	47.4	72	77	79	0.52	0.66	0.76		
5	3.7	6500	230	3450	1.15	16.1	17.7	110.4	73	77	78	0.57	0.7	0.74	11.9	30.3
			380		1.15	9.7	10.7	66.8	73	77	78	0.57	0.7	0.74		
			460		1.15	8.0	8.8	55.2	73	77	78	0.57	0.7	0.74		
6	4.5	6500	230	3445	1.15	18.4	20.2	127.4	71	75	76	0.61	0.73	0.81	13.1	45.4
			380		1.15	11.1	12.2	77.1	71	75	76	0.61	0.73	0.81		
			460		1.15	9.2	10.1	63.7	71	75	76	0.61	0.73	0.81		
7.5	5.5	6500	230	3445	1.15	23.6	25.9	190.2	73	77	78	0.54	0.65	0.75	17.8	57.5
			380		1.15	14.3	15.7	103	73	77	78	0.54	0.65	0.75		
			460		1.15	11.8	13.0	85.1	73	77	78	0.54	0.65	0.75		
10	7.5	6500	230	3430	1.15	34.0	37.4	210	76	77	78	0.52	0.6	0.71	23.9	85.7
			380		1.15	20.6	22.6	131	76	77	78	0.52	0.6	0.71		
			460		1.15	17.0	18.7	108	76	77	78	0.52	0.6	0.71		

4" ENCAPSULATED PREMIUM MOTOR

MOTOR LENGTH & WEIGHT SS 304/SS316 SINGLE/THREE PHASE

SUBMERSIBLE MOTORS				
Material	Stainless Steel 304/316		Rating	0.37 kW - 7.5 kW
Type	Encapsulated		Thrust Rating	1500 - 6500 N

PREMIUM 100 LENGTH & WEIGHTS (SINGLE PHASE)

PREMIUM-100 SS304				
P _N	P _N	L	Motor Package Size	Shipping
[HP]	[KW]	[mm]	[mm]	Weight[Kg]
0.5	0.37	223.5	126X126X500	8.42
0.75	0.55	238.5	126X126X500	8.96
1	0.75	252.5	126X126X500	8.96
1.5	1.1	273.5	126X126X500	10.40
2	1.5	386.5	126X126X650	12.36
3	2.2	386.5	126X126X650	28.28

PREMIUM-100 SS316				
P _N	P _N	L	Motor Package Size	Shipping
[HP]	[KW]	[mm]	[mm]	Weight[Kg]
0.5	0.37	223.5	126X126X500	8.42
0.75	0.55	238.5	126X126X500	8.96
1	0.75	252.5	126X126X500	8.96
1.5	1.1	273.5	126X126X500	10.40
2	1.5	386.5	126X126X650	12.36
3	2.2	386.5	126X126X650	28.28

PREMIUM 101 LENGTH & WEIGHTS (SINGLE PHASE)

PREMIUM-101 SS304				
P _N	P _N	L	Motor Package Size	Shipping
[HP]	[KW]	[mm]	[mm]	Weight[Kg]
5	3.7	538.5	126X126X900	28.00

PREMIUM-101 SS316				
P _N	P _N	L	Motor Package Size	Shipping
[HP]	[KW]	[mm]	[mm]	Weight[Kg]
5	3.7	538.5	126X126X900	28.00

PREMIUM 100 LENGTH & WEIGHTS (THREE PHASE)

PREMIUM-100 SS304				
P _N	P _N	L	Motor Package Size	Shipping
[HP]	[KW]	[mm]	[mm]	Weight[Kg]
0.75	0.55	238.5	126X126X500	8.96
1	0.75	252.5	126X126X500	8.96
1.5	1.1	273.5	126X126X500	10.40
2	1.5	386.5	126X126X650	12.36
3	2.2	386.5	126X126X650	28.28
4	3	499.5	126X126X650	28.28
5	3.7	538.5	126X126X900	30.00

PREMIUM-100 SS316				
P _N	P _N	L	Motor Package Size	Shipping
[HP]	[KW]	[mm]	[mm]	Weight[Kg]
0.75	0.55	238.5	126X126X500	8.96
1	0.75	252.5	126X126X500	8.96
1.5	1.1	273.5	126X126X500	10.40
2	1.5	386.5	126X126X650	12.36
3	2.2	386.5	126X126X650	28.28
4	3	499.5	126X126X650	28.28
5	3.7	538.5	126X126X900	30.00

PREMIUM 101 LENGTH & WEIGHTS (THREE PHASE)

PREMIUM-101 SS304				
P _N	P _N	L	Motor Package Size	Shipping
[HP]	[KW]	[mm]	[mm]	Weight[Kg]
5.5	4	563.5	126X126X1000	29.00
7.5	5.5	690	126X126X1000	29.00
10	7.5	746.5	126X126X1000	32.50

PREMIUM-101 SS316				
P _N	P _N	L	Motor Package Size	Shipping
[HP]	[KW]	[mm]	[mm]	Weight[Kg]
5.5	4	563.5	126X126X1000	29.00
7.5	5.5	690	126X126X1000	29.00
10	7.5	746.5	126X126X1000	32.50

* Single motor pack

4" ENCAPSULATED PREMIUM MOTOR



MOTOR OUTLINE DRAWINGS

www.shaktipumps.com

SUBMERSIBLE MOTORS			
Material	Stainless Steel 304/316	Rating	0.37 kW - 7.5 kW
Type	Encapsulated	Thrust Rating	1500 - 6500 N

MOTOR OUTLINE DRAWINGS

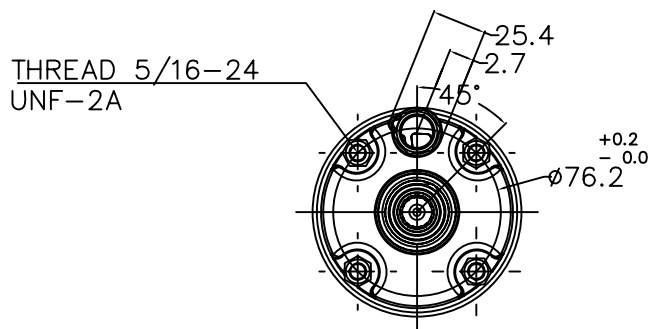
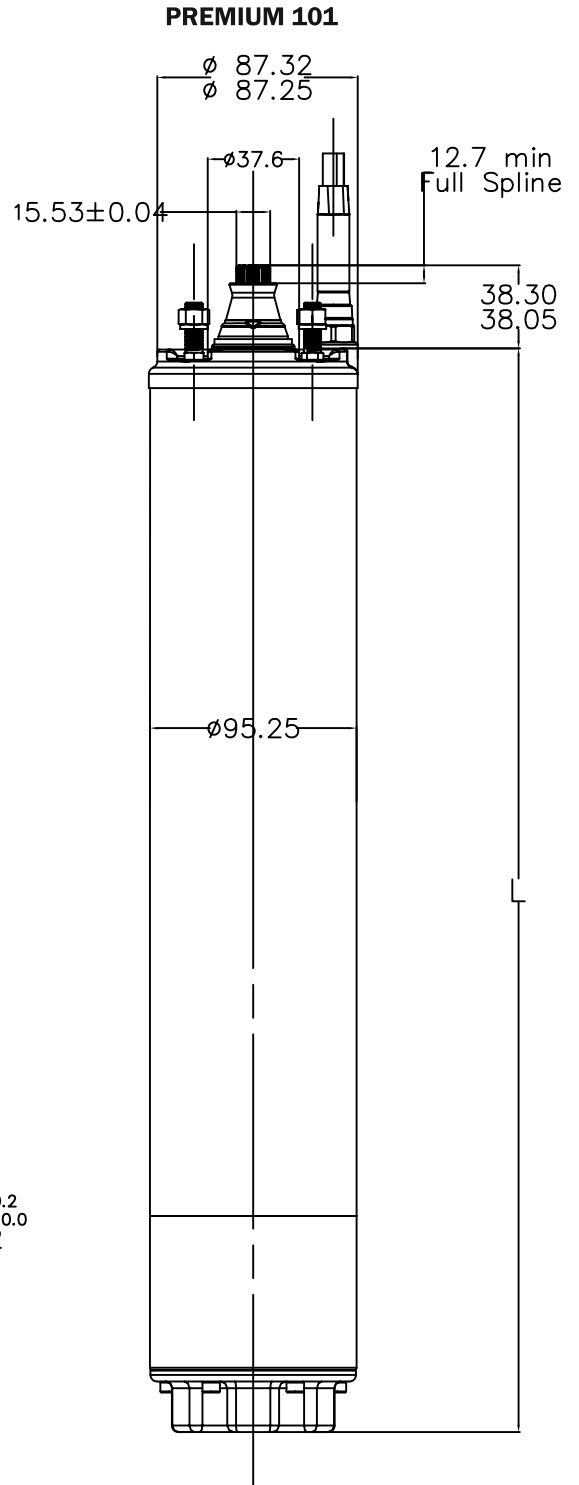
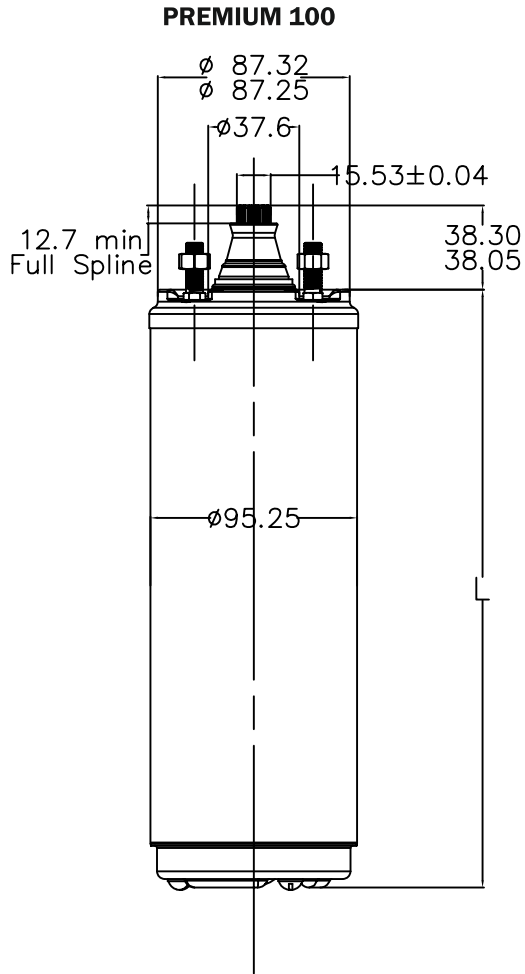

TOLERANCE ACCORDING TO NEMA MG 1 - 18.388

4" ENCAPSULATED PREMIUM MOTOR

MOTOR SECTIONAL VIEW MATERIAL CONSTRUCTION PREMIUM 100

SUBMERSIBLE MOTORS			
Material	Stainless Steel 304/316	Rating	0.37 kW - 7.5 kW
Type	Encapsulated	Thrust Rating	1500 - 6500 N

PREMIUM 100

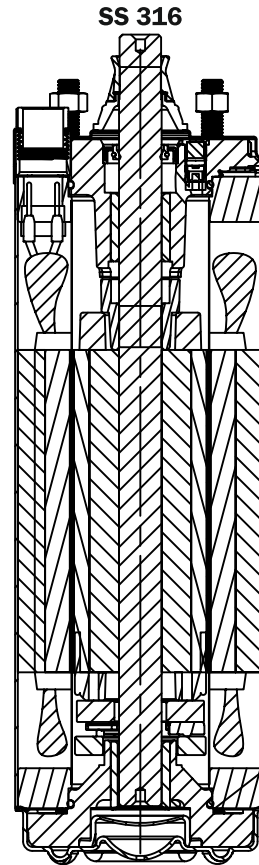
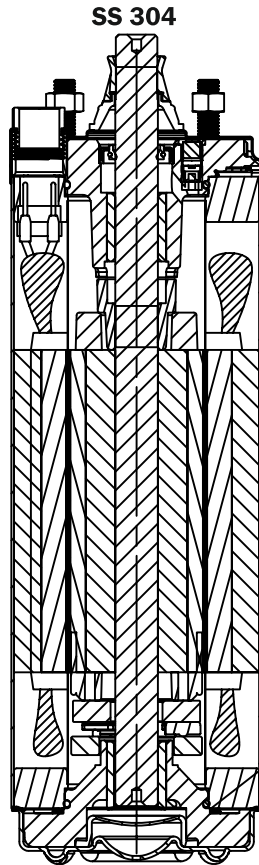

PART	MATERIAL
SAND SLINGER	NBR
SEAL COVER	PPS
OIL SEAL	NBR+ SS AISI 304
TOP END BELL COVER	SS AISI-304
TOP END BELL	CI FG-260
SHAFT BUSH	NYLON 30% GLASS FILLED
BUSH	CARBON WITH RESIGN IMPREGATED
ROTOR SHAFT	SS (STAINLESS STEEL SPECIAL GADE)
ROTOR SUB ASSLY	N/A
TOP FLANGE	MS
STATOR PIPE	SS AISI-304
STATOR SUB ASSLY	N/A
THRUST DISC	REGIN IMPREGNATED CARBON
THRUST PAD	SS AISI-420
LEVELING DISC	MS+ HARD CHROM
BOTTOM END BELL	CI FG-260
DIAPHRAGM	NBR
BOTTOM FLANGE	MS
BOTTOM END BELL COVER	SS AISI-304

PART	MATERIAL
SAND SLINGER	NBR
SEAL COVER	PPS
OIL SEAL	NBR+ SS AISI 304
TOP END BELL COVER	SS AISI-316
TOP END BELL	CI FG-260
SHAFT BUSH	NYLON 30% GLASS FILLED
BUSH	CARBON WITH RESIGN IMPREGATED
ROTOR SHAFT	SS (STAINLESS STEEL SPECIAL GADE)
ROTOR SUB ASSLY	N/A
TOP FLANGE	MS
STATOR PIPE	SS AISI-316
STATOR SUB ASSLY	N/A
THRUST DISC	REGIN IMPREGNATED CARBON
THRUST PAD	SS AISI-420
LEVELING DISC	MS+ HARD CHROM
BOTTOM END BELL	CI FG-260
DIAPHRAGM	NBR
BOTTOM FLANGE	MS
BOTTOM END BELL COVER	SS AISI-316

4" ENCAPSULATED PREMIUM MOTOR



MOTOR SECTIONAL VIEW MATERIAL CONSTRUCTION PREMIUM 101

www.shaktipumps.com

SUBMERSIBLE MOTORS			
Material	Stainless Steel 304/316	Rating	0.37 kW - 7.5 kW
Type	Encapsulated	Thrust Rating	1500 - 6500 N

PREMIUM 101

SS 304



SS 316



PART	MATERIAL
SAND SLINGER	NBR
SEAL COVER	PPS
OIL SEAL	NBR+ SS AISI 304
TOP END BELL COVER	SS AISI-304
TOP END BELL	CI FG-260
SHAFT BUSH	NYLON 30% GLASS FILLED
BUSH	CARBON WITH RESIGN IMPREGATED
ROTOR SHAFT	SS (STAINLESS STEEL SPECIAL GADE)
ROTOR SUB ASSLY	N/A
TOP FLANGE	MS
STATOR PIPE	SS AISI-304
STATOR SUB ASSLY	N/A
THRUST HOUSING	CI FG-260
THRUST PIPE	SS AISI-304
THRUST DISC	CI FG-260
CARBON PLATE	REGIN IMPREGNATED
LEVELING DISC	SS AISI 420
ADJUSTING STUD	SS AISI-410
BOTTOM END BELL	CI FG-260
DIAPHRAGM	NBR
BOTTOM FLANGE	MS
DIAPHRAGM COVER	SS AISI-304

PART	MATERIAL
SAND SLINGER	NBR
SEAL COVER	PPS
OIL SEAL	NBR+ SS AISI 304
TOP END BELL COVER	SS AISI-316
TOP END BELL	CI FG-260
SHAFT BUSH	NYLON 30% GLASS FILLED
BUSH	CARBON WITH RESIGN IMPREGATED
ROTOR SHAFT	SS (STAINLESS STEEL SPECIAL GADE)
ROTOR SUB ASSLY	N/A
TOP FLANGE	MS
STATOR PIPE	SS AISI-316
STATOR SUB ASSLY	N/A
THRUST HOUSING	CI FG-260
THRUST HOUSING	SS AISI-304
THRUST DISC	CI FG-260
CARBON PLATE	REGIN IMPREGNATED
LEVELING DISC	SS AISI 420
ADJUSTING STUD	SS AISI-410
BOTTOM END BELL	CI FG-260
DIAPHRAGM	NBR
BOTTOM FLANGE	MS
DIAPHRAGM COVER	SS AISI-316

4" ENCAPSULATED PREMIUM MOTOR

MOTOR ASSLY EXPLODED VIEW PRE - 100 SS 304

SUBMERSIBLE MOTORS			
Material	Stainless Steel 304/316	Rating	0.37 kW - 7.5 kW
Type	Encapsulated	Thrust Rating	1500 - 6500 N

MOTOR ASSLY EXPLODED VIEW PRE - 100 SS 304
MATERIAL NO. 900008274

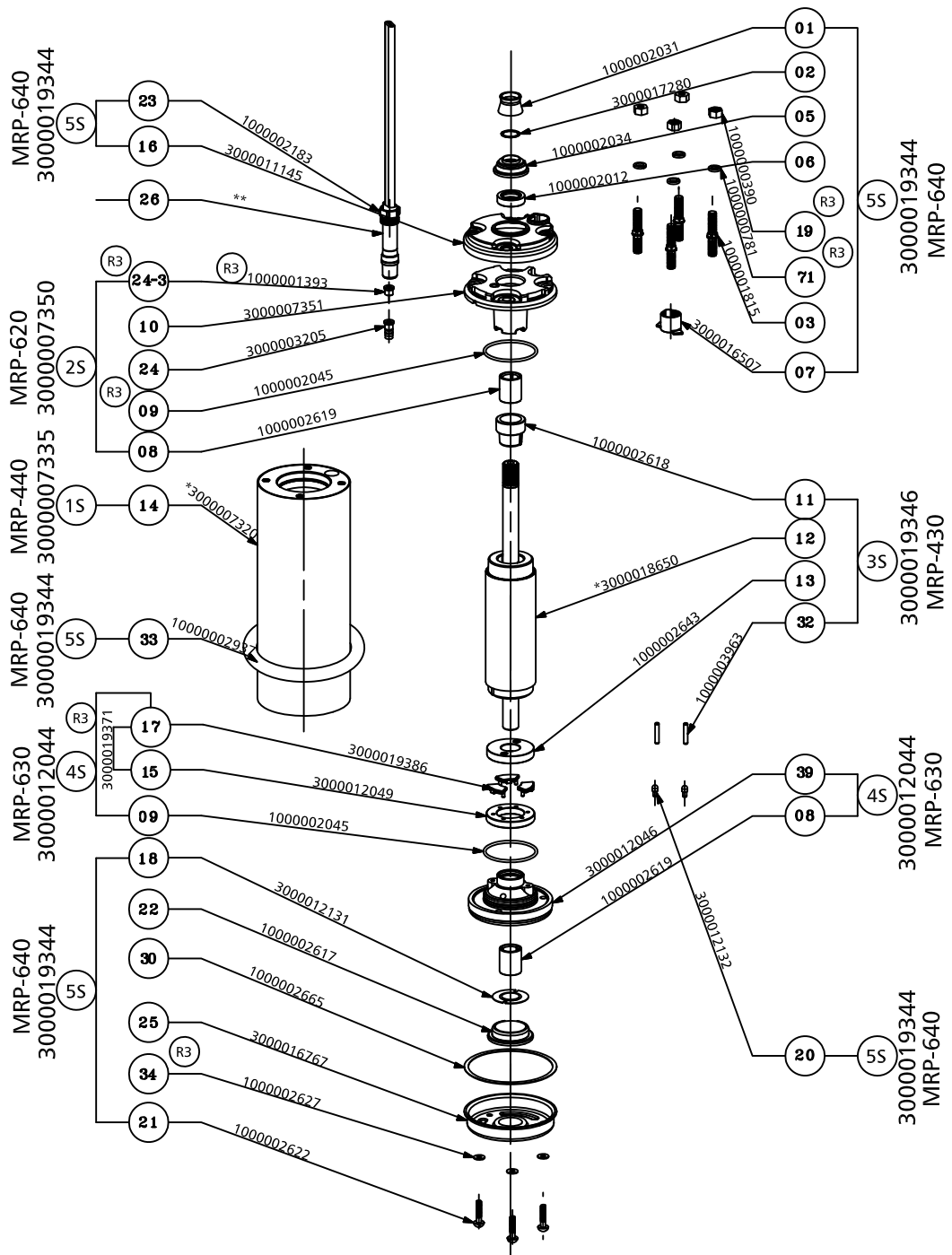

NOTE:- * INDICATES AS PER (HP)
** AS PER REQUIREMENT
MRP INDICATES MATERIAL REQUIREMENT PLANNING

4" ENCAPSULATED PREMIUM MOTOR



SECTIONAL VIEW PRE - 100 SS 304

www.shaktipumps.com

SUBMERSIBLE MOTORS			
Material	Stainless Steel 304/316	Rating	0.37 kW - 7.5 kW
Type	Encapsulated	Thrust Rating	1500 - 6500 N

SECTIONAL VIEW PRE - 100 SS 304
MATERIAL NO. 900008274

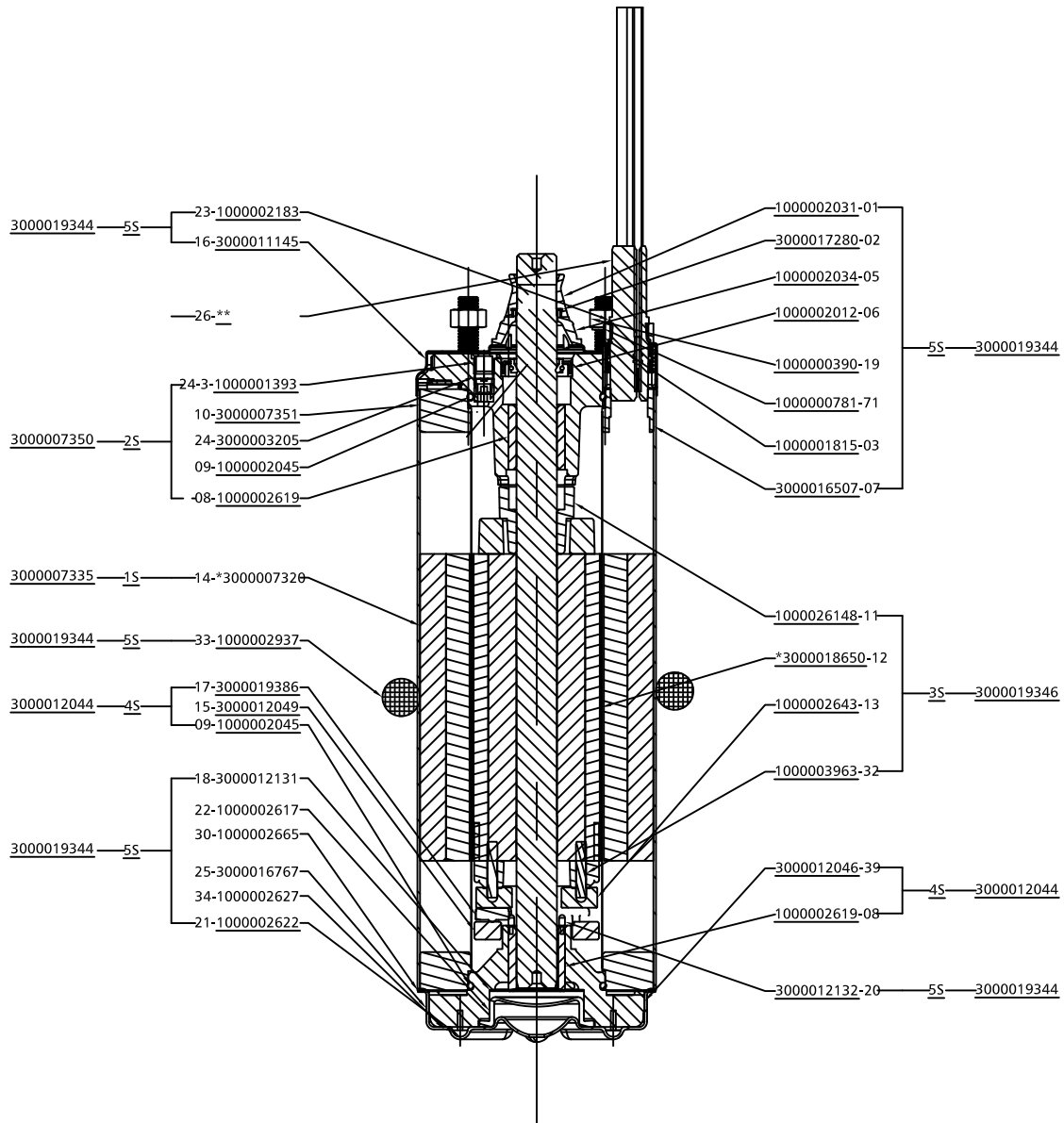

NOTE:- * INDICATES AS PER (HP)
 ** AS PER REQUIREMENT
 MRP INDICATES MATERIAL REQUIREMENT PLANNING

4" ENCAPSULATED PREMIUM MOTOR

PART LIST EXPLODED VIEW PRE - 100 SS 304

SUBMERSIBLE MOTORS			
Material	Stainless Steel 304/316	Rating	0.37 kW - 7.5 kW
Type	Encapsulated	Thrust Rating	1500 - 6500 N

PART LIST EXPLODED VIEW FOR PREMIUM 100 SS 304

GROUP	POS	MATERIAL CODE	PART DESCRIPTION	QTY	MATERIAL
5S 3000019344	1	1000002031	SAND SLINGER	1	NBR
	2	3000017280	SAND WASHER	1	SS AISI-304
	5	1000002034	SEAL COVER	1	PPS
	6	1000002012	OIL SEAL	1	NBR+ SS AISI 304
	19	1000000390	NUT	4	SS AISI-304
	71	1000000781	SPRING WASHER	4	SS AISI-304
	3	1000001815	STUD	4	SS AISI-304
	7	3000016507	CONNECTOR BOSS	1	NICKLE COATED
3S 3000019346	11	1000002618	SHAFT BUSH	1	NYLON 30% GLASS FILLED
	12	*3000018650	ROTOR SUB ASSLY	1	N/A
	13	1000002643	THRUST DISC	1	ANTIMONY CARBON
	32	1000003963	BOTTOM PIN	2	SS AISI-304
4S 3000012044	39	3000012046	BOTTEM ENDBELL	1	CI FG-260
	8	1000002619	BUSH	1	CARBON
5S 3000019344	20	3000012132	BOTTEM PIN	1	SS AISI-304
5S 3000019344	23	1000002183	CONNECTOR LUG	1	SS AISI-304
	16	3000011145	TOP ENDBELL COVER	1	SS AISI-304
	26	**	CABLE	1	RUBBER
2S 3000007350	24-3	1000001393	FILTER	1	PP
	10	3000007351	TOP ENDBELL	1	CI FG-260
	24	3000003205	PRESSURE RELIFE VALVE ASSLY	1	N/A
	9	1000002045	O-RING	1	NBR
	8	1000002619	BUSH	1	CARBON
1S 3000007335	14	*3000007320	STATOR SUB ASSLY	1	N/A
5S 3000019344	33	1000002937	CABLE GUARD	1	RUBBER
4S 3000012044	17	3000019386	THRUST PAD	3	SS AISI-420
	15	3000012049	LEVELING DISC	1	MS+HARD CROM
	9	1000002045	O-RING	1	NBR
5S 3000019344	18	3000012131	DIAPHRAM INSERT	1	SS AISI-304
	22	1000002617	DIAPHRAM	1	NBR
	30	1000002665	GASKET BOTTOM	1	
	25	3000016767	BOTTEM ENDBELL COVER	1	SS AISI-304
	34	1000002627	PVC WASHER	3	PVC
	21	1000002622	ALLEN M5X32	3	SS AISI-304

NOTE:- * INDICATES AS PER (HP)

** AS PER REQUIREMENT

MRP INDICATES MATERIAL REQUIREMENT PLANNING

4" ENCAPSULATED PREMIUM MOTOR

SECTIONAL VIEW PRE - 100 SS 316

SUBMERSIBLE MOTORS			
Material	Stainless Steel 304/316	Rating	0.37 kW - 7.5 kW
Type	Encapsulated	Thrust Rating	1500 - 6500 N

SECTIONAL VIEW PRE - 100 SS 316
MATERIAL NO. 900008274

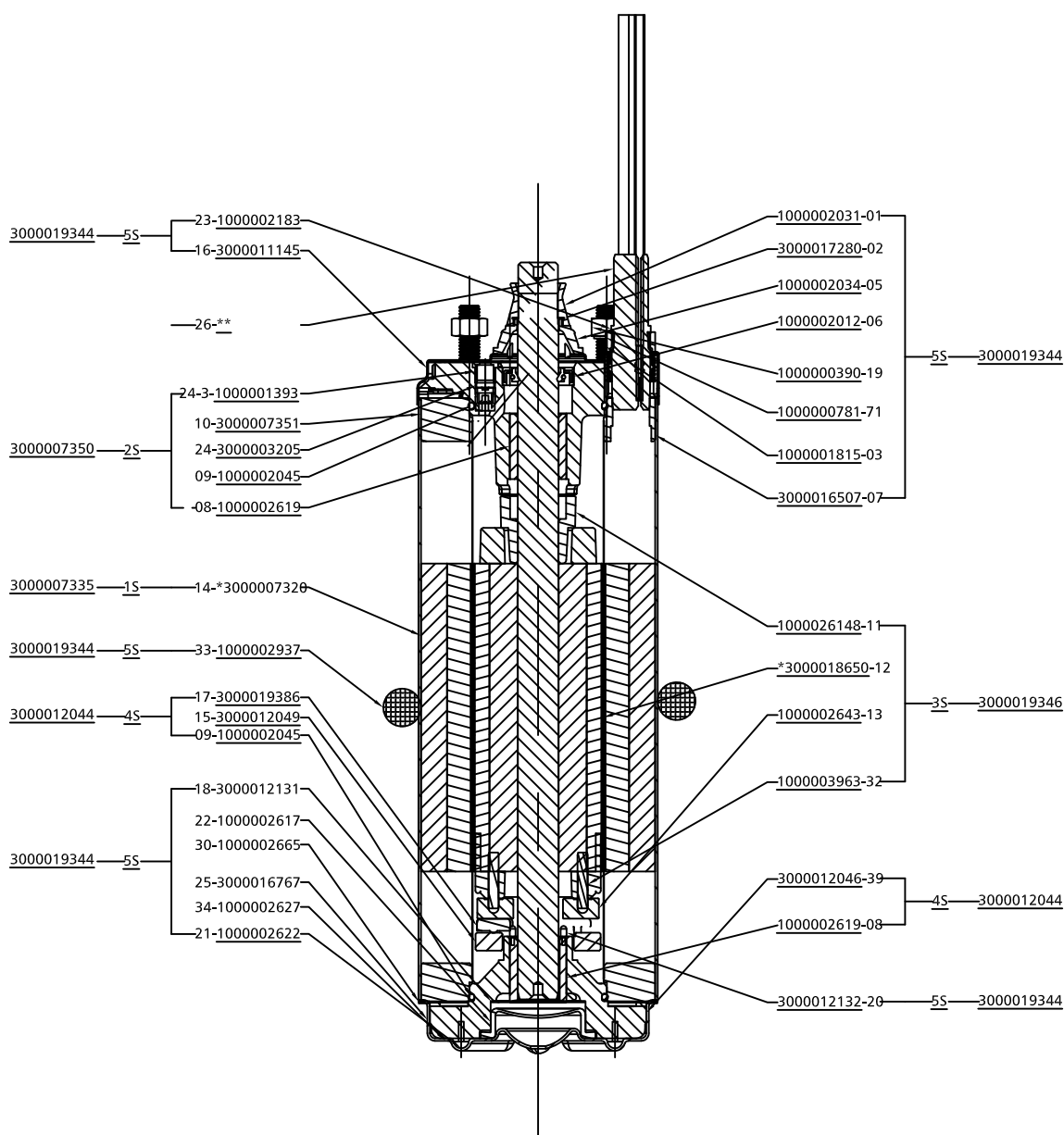

NOTE:- * INDICATES AS PER (HP)
 ** AS PER REQUIREMENT
 MRP INDICATES MATERIAL REQUIREMENT PLANNING

4" ENCAPSULATED PREMIUM MOTOR



PART LIST EXPLODED FOR PREMIUM 100 SS 316

www.shaktipumps.com

SUBMERSIBLE MOTORS			
Material	Stainless Steel 304/316	Rating	0.37 kW - 7.5 kW
Type	Encapsulated	Thrust Rating	1500 - 6500 N

PART LIST EXPLODED VIEW FOR PREMIUM 100 SS 316

GROUP	POS	MATERIAL CODE	PART DESCRIPTION	QTY	MATERIAL
5S 3000019344	1	1000002031	SAND SLINGER	1	NBR
	2	3000017280	SAND WASHER	1	SS AISI-304
	5	1000002034	SEAL COVER	1	PPS
	6	1000002012	OIL SEAL	1	NBR+ SS AISI 304
	19	1000000390	NUT	4	SS AISI-304
	71	1000000781	SPRING WASHER	4	SS AISI-304
	3	1000001815	STUD	4	SS AISI-304
	7	3000016507	CONNECTOR BOSS	1	NICKLE COATED
3S 3000019346	11	1000002618	SHAFT BUSH	1	NYLON 30% GLASS FILLED
	12	*3000018650	ROTOR SUB ASSLY	1	N/A
	13	1000002643	THRUST DISC	1	ANTIMONY CARBON
	32	1000003963	BOTTOM PIN	2	SS AISI-304
4S 3000012044	39	3000012046	BOTTEM ENDBELL	1	CI FG-260
	8	1000002619	BUSH	1	CARBON
5S 3000019344	20	3000012132	BOTTEM PIN	1	SS AISI-304
5S 3000019344	23	1000002183	CONNECTOR LUG	1	SS AISI-304
	16	3000011145	TOP ENDBELL COVER	1	SS AISI-316
	26	**	CABLE	1	RUBBER
2S 3000007350	24-3	1000001393	FILTER	1	PP
	10	3000007351	TOP ENDBELL	1	CI FG-260
	24	3000003205	PRESSURE RELIFE VALVE ASSLY	1	N/A
	9	1000002045	O-RING	1	NBR
	8	1000002619	BUSH	1	CARBON
1S 3000007335	14	*3000007320	STATOR SUB ASSLY	1	N/A
5S 3000019344	33	1000002937	CABLE GUARD	1	RUBBER
4S 3000012044	17	3000019386	THRUST PAD	3	SS AISI-420
	15	3000012049	LEVELING DISC	1	MS+HARD CROM
	9	1000002045	O-RING	1	NBR
5S 3000019344	18	3000012131	DIAPHRAM INSERT	1	SS AISI-304
	22	1000002617	DIAPHRAM	1	NBR
	30	1000002665	GASKET BOTTOM	1	
	25	3000016767	BOTTEM ENDBELL COVER	1	SS AISI-316
	34	1000002627	PVC WASHER	3	PVC
	21	1000002622	ALLEN M5X32	3	SS AISI-304

NOTE:- * INDICATES AS PER (HP)

** AS PER REQUIREMENT

MRP INDICATES MATERIAL REQUIREMENT PLANNING

4" ENCAPSULATED PREMIUM MOTOR

MOTOR ASSLY EXPLODED VIEW PRE - 101 SS 304

SUBMERSIBLE MOTORS			
Material	Stainless Steel 304/316	Rating	0.37 kW - 7.5 kW
Type	Encapsulated	Thrust Rating	1500 - 6500 N

MOTOR ASSLY EXPLODED VIEW PRE - 101 SS 304
MATERIAL NO. 900008307

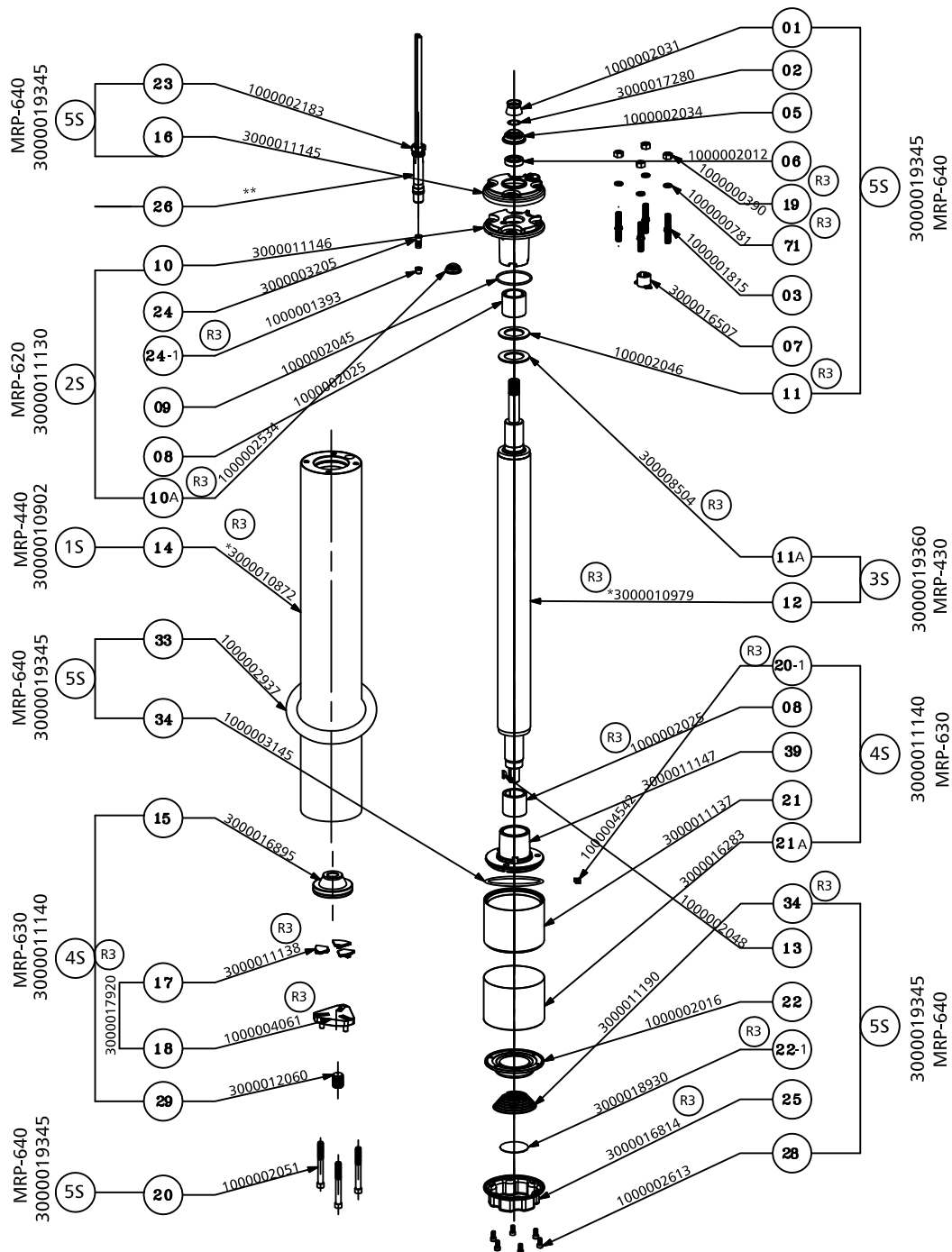

NOTE:- * INDICATES AS PER (HP)
** AS PER REQUIREMENT
MRP INDICATES MATERIAL REQUIREMENT PLANNING

4" ENCAPSULATED PREMIUM MOTOR



SECTIONAL VIEW PRE - 101 SS 304

www.shaktipumps.com

SUBMERSIBLE MOTORS			
Material	Stainless Steel 304/316	Rating	0.37 kW - 7.5 kW
Type	Encapsulated	Thrust Rating	1500 - 6500 N

SECTIONAL VIEW PRE - 101 SS 304
MATERIAL NO. 900008307

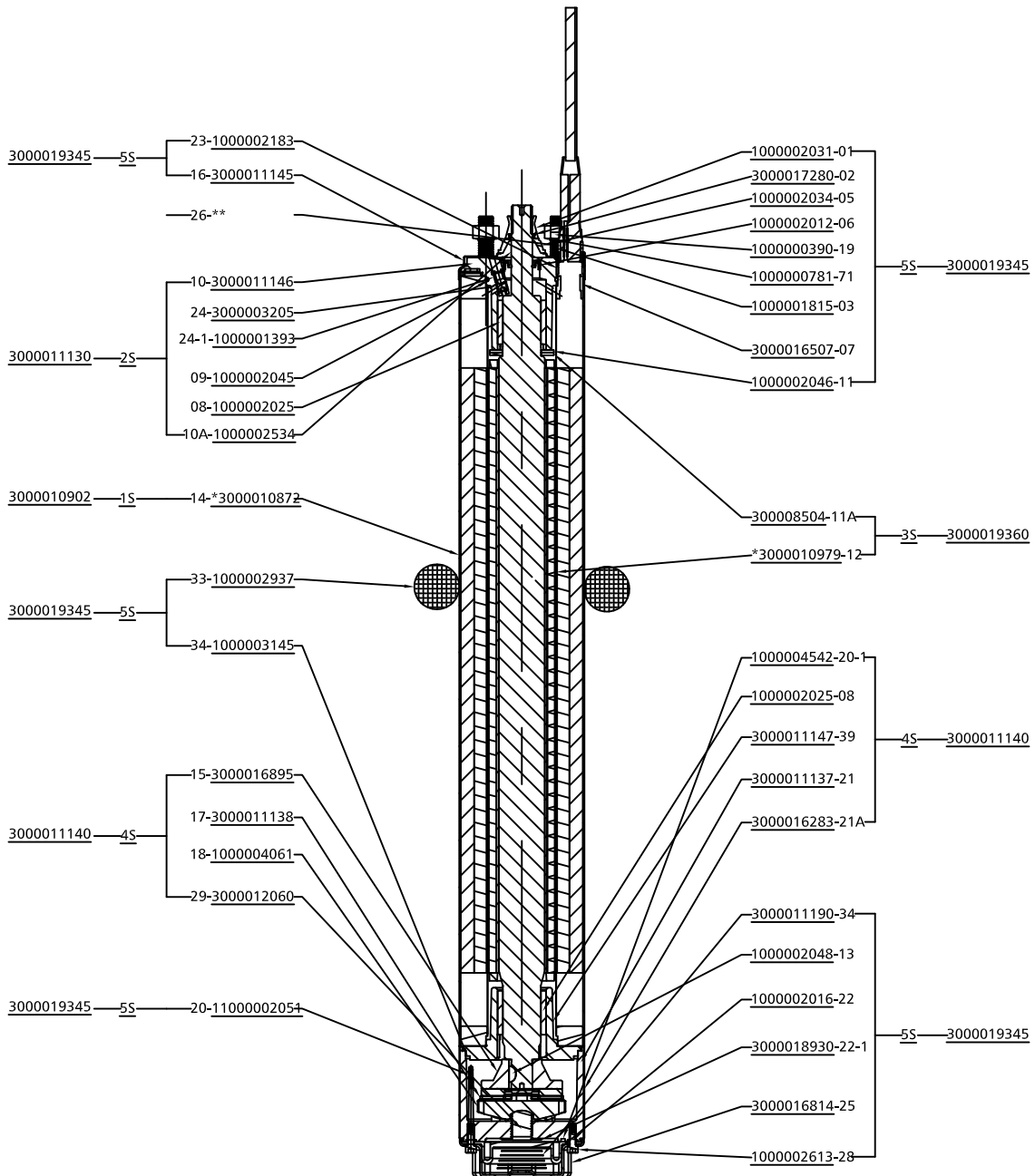

NOTE:- * INDICATES AS PER (HP)
 ** AS PER REQUIREMENT
 MRP INDICATES MATERIAL REQUIREMENT PLANNING

4" ENCAPSULATED PREMIUM MOTOR

PART LIST EXPLODED FOR PREMIUM 101 SS 304

SUBMERSIBLE MOTORS			
Material	Stainless Steel 304/316	Rating	0.37 kW - 7.5 kW
Type	Encapsulated	Thrust Rating	1500 - 6500 N

PART LIST EXPLODED VIEW FOR PREMIUM 101 SS 304

GROUP	POS	MATERIAL CODE	PART DESCRIPTION	QTY	MATERIAL
5S 3000019345	1	1000002031	SAND SLINGER	1	NBR
	2	3000017280	SAND WASHER	1	SS AISI-304
	5	1000002034	SEAL COVER	1	PPS
	6	1000002012	OIL SEAL	1	NBR+ SS AISI 304
	19	1000000390	NUT	4	SS AISI-304
	71	1000000781	SPRING WASHER	4	SS AISI-304
	3	1000001815	STUD	4	SS AISI-304
	7	3000016507	CONNECTOR BOSS	1	NICKLE COATED
	11	1000002046	UP THRUST WASHER	1	PVC
3S 3000019360	11A	1000003504	SS WASHER	1	SS AISI-304
	12	*3000010979	ROTOR SUB ASSLY	1	N/A
4S 3000011140	20-1	1000004542	MAGNET	1	MAGNET
	8	1000002025	BUSH CARBON	1	CARBON
	39	3000011147	BOTTOM END BELL	1	CI FG-260
	21	3000011137	THRUST HOUSING	1	CI FG-260
	21A	3000016283	THRUST HOUSING PIPE	1	SS AISI-304
5S 3000019345	34	3000011190	DIAPHRAM SPRING	1	SS
	13	1000002048	WOOD RUF KEY	1	SS AISI-304
	22	1000002016	DIAPHRAGM	1	NBR
	22-1	3000018930	DIAPHRAM INSERT		SS AISI-304
	25	3000016814	DIAPHRAGM COVER	1	SS AISI-304
5S 3000019345	28	1000002613	ALLEN BOLT M5X10MM	6	SS AISI-304
	23	1000002183	CONNECTOR LUG	1	SS AISI-304
	16	3000011145	TOP END BELL COVER	1	SS AISI-304
	26	**	CABLE	1	RUBBER
2S 3000011130	10	3000011146	TOP END BELL	1	CI FG-260
	24	3000003205	PRESSURE RELIEF VALVE ASSLY	1	N/A
	24-1	1000001393	FILTER	1	PP
	9	1000002045	O-RING	1	NBR
	8	1000002025	BUSH CARBON	1	CARBON
	10A	1000002534	CAP TOP END BELL	1	
1S 3000010902	14	*3000010872	STATOR SUB ASSLY	1	N/A
5S 3000019345	33	1000002937	CABLE GUARD	1	RUBBER
	34	1000003145	O -RING	1	NBR
4S 3000011140	15	3000016895	THRUST DISC ASSLY	1	CI FG-260
	17	3000011138	SEGMENT	3	SS AISI-420
	18	1000001061	LEVELING DISK	1	SS AISI 410
	29	3000012060	ADJUSTING STUD	1	SS AISI-410
5S 3000019345	20	1000002051	ALLEN BOLT M8X70MM	3	SS AISI-304

NOTE:- * INDICATES AS PER (HP)

** AS PER REQUIREMENT

MRP INDICATES MATERIAL REQUIREMENT PLANNING

4" ENCAPSULATED PREMIUM MOTOR

MOTOR ASSLY EXPLODED VIEW PRE - 101 SS 316



www.shaktipumps.com

SUBMERSIBLE MOTORS			
Material	Stainless Steel 304/316	Rating	0.37 kW - 7.5 kW
Type	Encapsulated	Thrust Rating	1500 - 6500 N

MOTOR ASSLY EXPLODED VIEW PRE - 101 SS 316
MATERIAL NO. 900008307

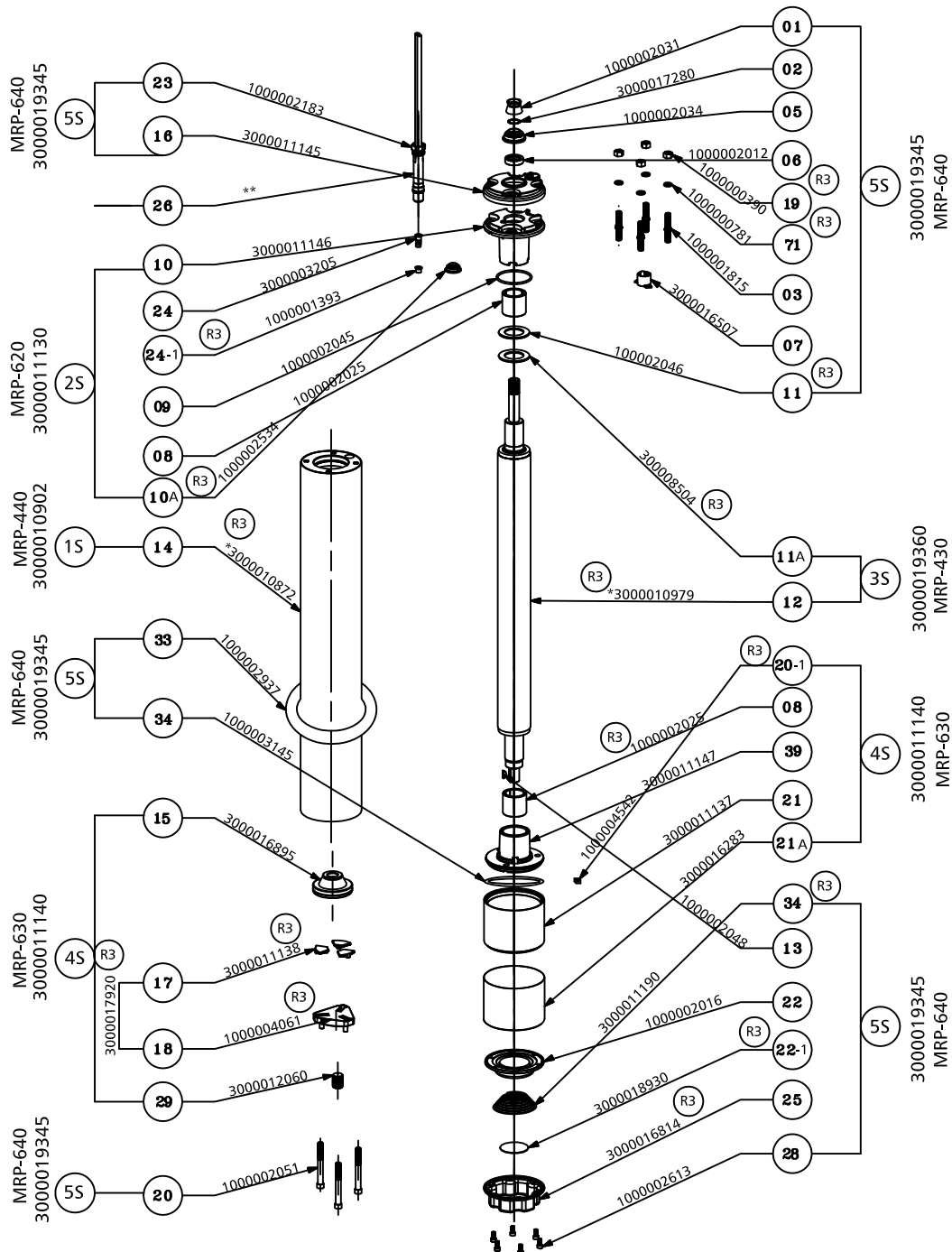

NOTE:- * INDICATES AS PER (HP)
** AS PER REQUIREMENT
MRP INDICATES MATERIAL REQUIREMENT PLANNING

4" ENCAPSULATED PREMIUM MOTOR

SECTIONAL VIEW PRE - 101 SS 316

SUBMERSIBLE MOTORS			
Material	Stainless Steel 304/316	Rating	0.37 kW - 7.5 kW
Type	Encapsulated	Thrust Rating	1500 - 6500 N

SECTIONAL VIEW PRE - 101 SS 316
MATERIAL NO. 900008307

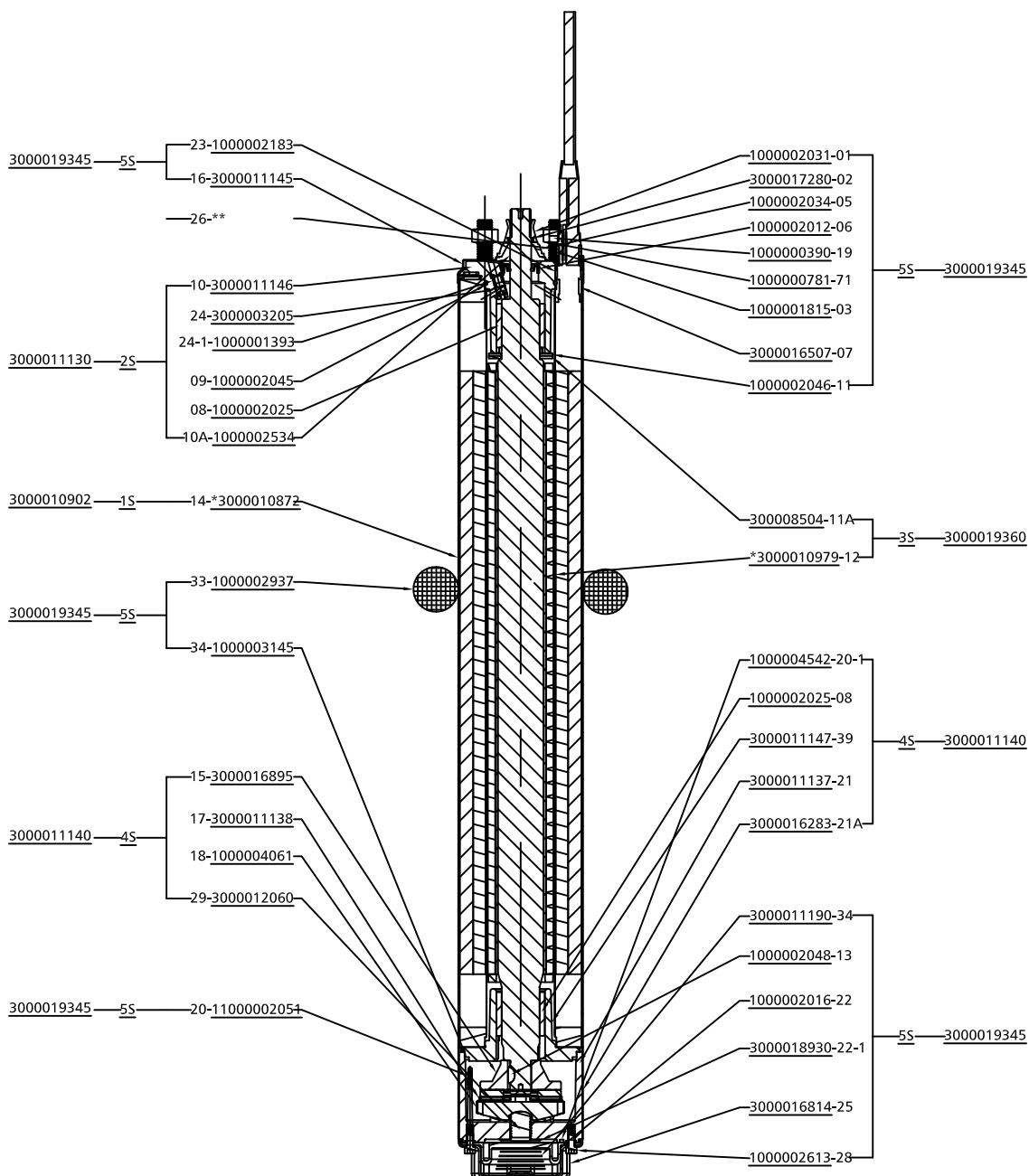

NOTE:- * INDICATES AS PER (HP)
 ** AS PER REQUIREMENT
 MRP INDICATES MATERIAL REQUIREMENT PLANNING

4" ENCAPSULATED PREMIUM MOTOR



PART LIST EXPLODED VIEW PRE - 101 SS 316

www.shaktipumps.com

SUBMERSIBLE MOTORS			
Material	Stainless Steel 304/316	Rating	0.37 kW - 7.5 kW
Type	Encapsulated	Thrust Rating	1500 - 6500 N

PART LIST EXPLODED VIEW FOR PREMIUM 101 SS 316

GROUP	POS	MATERIAL CODE	PART DESCRIPTION	QTY	MATERIAL
5S 3000019345	1	1000002031	SAND SLINGER	1	NBR
	2	3000017280	SAND WASHER	1	SS AISI-304
	5	1000002034	SEAL COVER	1	PPS
	6	1000002012	OIL SEAL	1	NBR+ SS AISI 304
	19	1000000390	NUT	4	SS AISI-304
	71	1000000781	SPRING WASHER	4	SS AISI-304
	3	1000001815	STUD	4	SS AISI-304
	7	3000016507	CONNECTOR BOSS	1	NICKLE COATED
3S 3000019360	11	1000002046	UP THRUST WASHER	1	PVC
	11A	1000003504	SS WASHER	1	SS AISI-304
4S 3000011140	12	*3000010979	ROTOR SUB ASSLY	1	N/A
	20-1	1000004542	MAGNET	1	MAGNET
	8	1000002025	BUSH CARBON	1	CARBON
	39	3000011147	BOTTOM END BELL	1	CI FG-260
	21	3000011137	THRUST HOUSING	1	CI FG-260
5S 3000019345	21A	3000016283	THRUST HOUSING PIPE	1	SS AISI-316
	34	3000011190	DIAPHRAM SPRING	1	SS
	13	1000002048	WOOD RUF KEY	1	SS AISI-304
	22	1000002016	DIAPHRAGM	1	NBR
	22-1	3000018930	DIAPHRAM INSERT		SS AISI-304
	25	3000016814	DIAPHRAGM COVER	1	SS AISI-316
5S 3000019345	28	1000002613	ALLEN BOLT M5X10MM	6	SS AISI-304
	23	1000002183	CONNECTOR LUG	1	SS AISI-304
	16	3000011145	TOP END BELL COVER	1	SS AISI-316
	26	**	CABLE	1	RUBBER
2S 3000011130	10	3000011146	TOP END BELL	1	CI FG-260
	24	3000003205	PRESSURE RELIEF VALVE ASSLY	1	N/A
	24-1	1000001393	FILTER	1	PP
	9	1000002045	O-RING	1	NBR
	8	1000002025	BUSH CARBON	1	CARBON
	10A	1000002534	CAP TOP END BELL	1	
1S 3000010902	14	*3000010872	STATOR SUB ASSLY	1	N/A
5S 3000019345	33	1000002937	CABLE GUARD	1	RUBBER
	34	1000003145	O -RING	1	NBR
4S 3000011140	15	3000016895	THRUST DISC ASSLY	1	CI FG-260
	17	3000011138	SEGMENT	3	SS AISI-420
	18	1000001061	LEVELING DISK	1	SS AISI 410
	29	3000012060	ADJUSTING STUD	1	SS AISI-410
5S 3000019345	20	1000002051	ALLEN BOLT M8X70MM	3	SS AISI-304

4" ENCAPSULATED PREMIUM MOTOR

STATOR AND ROTOR SPARE PARTS NUMBERS

SUBMERSIBLE MOTORS			
Material	Stainless Steel 304/316	Rating	0.37 kW - 7.5 kW
Type	Encapsulated	Thrust Rating	1500 - 6500 N

4" ENCAPSULATED PREMIUM-100

Replacement Rotors Assly

P _N		Rotor	Rotor Model No
[HP]	[KW]		
0.50	0.37	ROTOR ASSLY	3000019346
0.75	0.55	ROTOR ASSLY	3000019347
1.00	0.75	ROTOR ASSLY	3000019348
1.50	1.10	ROTOR ASSLY	3000019349
2.00	1.50	ROTOR ASSLY	3000019350
3.00	2.20	ROTOR ASSLY	3000019351
4.00	3.00	ROTOR ASSLY	3000019352

Replacement Stator Assly

P _N		Stator	Stator Model No
[HP]	[KW]		
0.50	0.37	ROTOR ASSLY	3000019346
0.50	0.37	STATOR ASSLY	3000007335
0.50	0.37	STATOR ASSLY	3000019086
0.50	0.37	STATOR ASSLY	3000019096
0.50	0.37	STATOR ASSLY	3000007340
0.75	0.55	STATOR ASSLY	3000007336
0.75	0.55	STATOR ASSLY	3000019087
0.75	0.55	STATOR ASSLY	3000019097
0.75	0.55	STATOR ASSLY	3000007341
0.75	0.55	STATOR ASSLY	3000007346
1.00	0.75	STATOR ASSLY	3000007337
1.00	0.75	STATOR ASSLY	3000019088
1.00	0.75	STATOR ASSLY	3000019098
1.00	0.75	STATOR ASSLY	3000007342
1.00	0.75	STATOR ASSLY	3000007347
1.50	1.10	STATOR ASSLY	3000007338
1.50	1.10	STATOR ASSLY	3000019089
1.50	1.10	STATOR ASSLY	3000019099
1.50	1.10	STATOR ASSLY	3000007348
2.00	1.50	STATOR ASSLY	3000007339
2.00	1.50	STATOR ASSLY	3000019090
2.00	1.50	STATOR ASSLY	3000019100
2.00	1.50	STATOR ASSLY	3000018863
2.00	1.50	STATOR ASSLY	3000018865
3.00	2.20	STATOR ASSLY	3000018855
3.00	2.20	STATOR ASSLY	3000018858
3.00	2.20	STATOR ASSLY	3000018861
3.00	2.20	STATOR ASSLY	3000018864
3.00	2.20	STATOR ASSLY	3000018866
4.00	3.00	STATOR ASSLY	3000018856
4.00	3.00	STATOR ASSLY	3000018859
4.00	3.00	STATOR ASSLY	3000018862

4" ENCAPSULATED PREMIUM MOTOR

STATOR AND ROTOR SPARE PARTS NUMBERS



www.shaktipumps.com

SUBMERSIBLE MOTORS			
Material	Stainless Steel 304/316	Rating	0.37 kW - 7.5 kW
Type	Encapsulated	Thrust Rating	1500 - 6500 N

4" ENCAPSULATED PREMIUM-101

Replacement Rotors Assly

P_N		Rotor	Rotor Model No
[HP]	[KW]		
5.0	3.7	ROTOR ASSLY	3000019360
5.5	4.0	ROTOR ASSLY	3000019353
7.5	5.5	ROTOR ASSLY	3000019354
10.0	7.5	ROTOR ASSLY	3000019355

Replacement Stator Assly

P_N		Stator	Stator Model No
[HP]	[KW]		
3.00	2.20	STATOR ASSLY	3000010918
5.00	3.70	STATOR ASSLY	3000010902
5.00	3.70	STATOR ASSLY	3000010908
5.00	3.70	STATOR ASSLY	3000010914
5.00	3.70	STATOR ASSLY	3000010920
5.00	3.70	STATOR ASSLY	3000010926
5.50	4.00	STATOR ASSLY	3000010903
5.50	4.00	STATOR ASSLY	3000010909
5.50	4.00	STATOR ASSLY	3000010915
7.50	5.50	STATOR ASSLY	3000010904
7.50	5.50	STATOR ASSLY	3000010910
7.50	5.50	STATOR ASSLY	3000010916
10.00	7.50	STATOR ASSLY	3000010905
10.00	7.50	STATOR ASSLY	3000010911
10.00	7.50	STATOR ASSLY	3000010917



STAR EXPORT HOUSE
Certificate Holder



India : Toll Free No. 1800 103 5657, +91-731 - 4253600

Other Countries : +91-7292 410500

SHAKTI PUMPS (I) LTD.

Regd. Office & Works : Plot No.401, Sector - 3, Pithampur - 454774, Dist.- Dhar (M.P.) - INDIA

Fax: +91-7292-407044

E-mail : info@shaktipumps.com, sales@shaktipumps.com, Visit us at : www.shaktipumps.com